



KATHOLIEKE UNIVERSITEIT
LEUVEN

Faculty of Economics and
Applied Economics

Department of Economics

The Oosterweel junction revisited
by

Saskia VAN DER LOO
Stef PROOST

Energy Transport and Environment

Center for Economic Studies
Discussions Paper Series (DPS) 10.07
<http://www.econ.kuleuven.be/ces/discussionpapers/default.htm>



March 2010

**DISCUSSION
PAPER**

The Oosterweel junction revisited

S. van der Loo¹,

S. Proost

KULeuven, March 2010

Abstract:

This paper assesses the Oosterweel junction, a new tunnel under the river Scheldt, that aims to alleviate the congestion on the existing tunnels and on the Ring of Antwerp. The paper uses data from existing studies of the same project to calibrate a simple network model (MOLINO-II). The model is then used to compare alternatives with and without the new tunnel. The alternatives include different combinations of tolls and bans on trucks. The study concludes that the first priority is not to build new capacity but to remove the pricing distortions on the existing capacity. The alternatives that include a pricing reform are the only ones that generate a positive net benefit, almost all scenarios that include the new tunnel have a negative net benefit.

¹ We thank “Steunpunt Fiskaliteit and Begroting” of the Flemish Government for financial support and the Verkeerscentrum Vlaanderen for making some of their traffic data available.

1. Introduction

The purpose of this paper is to use a transport model to assess the costs and benefits of several tunnel investment and tolling schemes in Antwerp, Belgium. Antwerp straddles the Scheldt river as shown in Figure 1-1. Three tunnels cross the Scheldt: one very small tunnel in the city centre (the Waasland tunnel-“wlt” on the map), the Kennedy tunnel (KEN) to the south and the Liefkenshoek tunnel (LFK) far north of the city. The Kennedy tunnel lies on the ring road that circles the centre of Antwerp to the east of the Scheldt. Traffic in Antwerp is heavy on weekdays, and congestion is particularly severe on the Kennedy tunnel which conveys a daily two-way flow of about 125,000 vehicles. This is in sharp contrast with the LFK which carries a much smaller daily flow of about 20,000 vehicles. The ring road is a crossroad for several motorways, and it is heavily used by cars and for national and international/transit freight transport.

A proposal has been made to build an additional tunnel under the Scheldt between the Kennedy and Liefkenshoek tunnels. The future tunnel², known as the “Oosterweel junction” (or for short OWV), would branch off the ring road and offer a shorter route for traffic heading to or from the north of Antwerp. Building a new tunnel would alleviate traffic congestion through the Kennedy tunnel and on the ring road generally. In addition it would facilitate the access to the port of Antwerp.

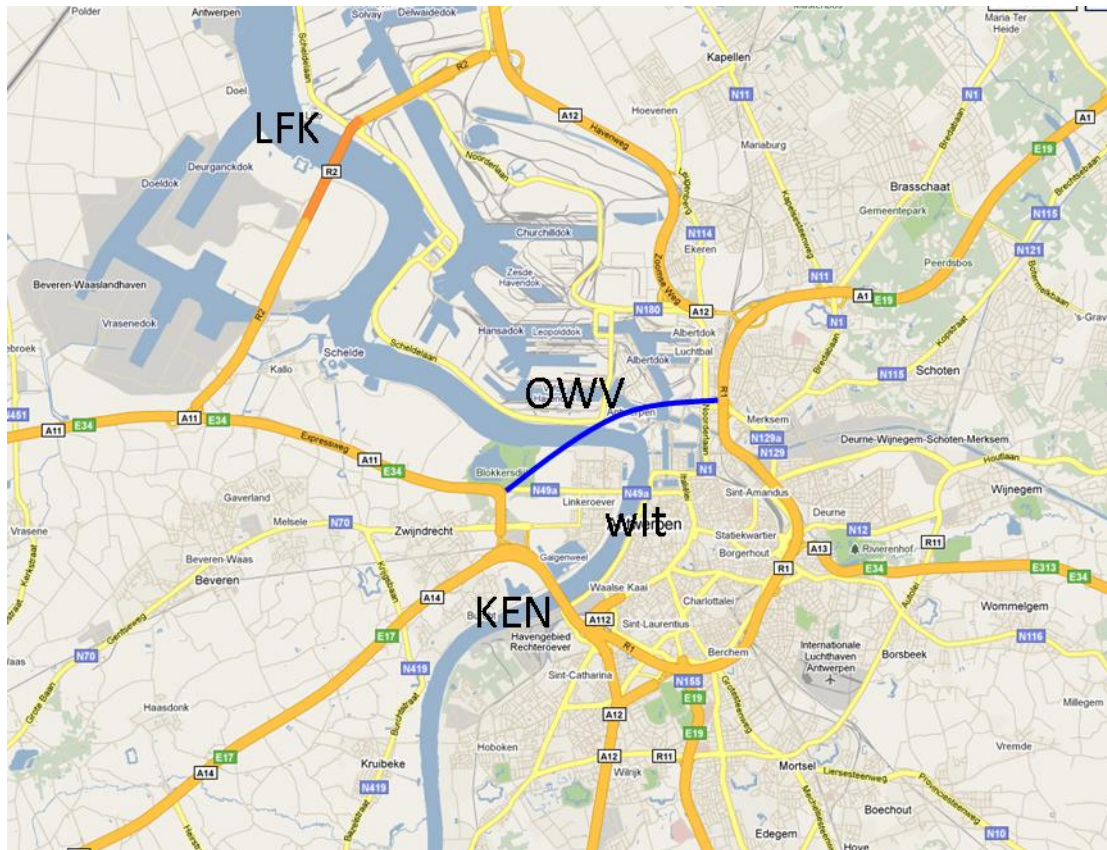

Figure 1-1: Antwerp

The new tunnel is expected to cost €1.35 billion³ (price level 2004, BAM (2004)). Part of this cost should be covered by the revenues raised by tolling the infrastructure. The agreed level of the tolls is 2 euro for passenger cars and 13 euro for trucks above 3.5 tons (all prices are VAT excluded). Together with the toll on the new infrastructure, freight will be banned from the Kennedy tunnel.

² For brevity it is called a tunnel here, but it is actually a combination of a tunnel and a bridge.

³ This is the cost of the tunnel only, the cost of the “Masterplan” of which the tunnel is part of is estimated at €2.25 billion.

Although there is a clear mobility problem in the Antwerp area, the new proposal has been subject to much criticism. A lot of these discussions were, however, focused on the precise trajectory of the infrastructure and other specifications of the tunnel. In this paper we do not wish to go into this discussion. We want to broaden the discussion and consider also alternative solutions. For example, is it not possible to solve, at least part, of the mobility problem around Antwerp with a better pricing of the existing infrastructure avoiding such expensive investments? Is the banning of freight in the Kennedy tunnel welfare improving or is it just a means to divert traffic to the tolled tunnel to generate revenues?

It is therefore of interest to compare several alternative investment and tolling regimes. In total nine scenarios will be compared, five where the new tunnel is not built and four with the new OWV.

The five scenarios without any new investment are (1) the business as usual scenario, where no new pricing nor investment is undertaken; (2) refrain from building the new tunnel, but ban freight from the KEN to alleviate congestion in the tunnel and on the ring road; (3) set tolls equal to zero in the LFK to attract traffic into this underused tunnel; (4) introduce a kilometercharge on the Belgian motorway network for trucks and keep actual tolling on LFK; (5) to alleviate congestion in the KEN, by charging a toll on the KEN for trucks and cars.

If the OWV is built, four possible scenarios are of interest: (1) the OWV is built but remains untolled; (2) the OWV is tolled as proposed but the KEN remains free for freight; (3) the proposal is applied in its entirety (tolls and ban on freight in the KEN); (4) instead of a ban, the KEN is tolled.

For the comparison of the different scenarios we use the MOLINO-II model which is described in section 3. In Section 2, we briefly review the existing studies concerning the new crossing. After the description of the model and how it is applied to the project in Section 3, we discuss the basic data and calibration of the model in Section 4. Section 5 analyzes the results and section 6 concludes.

2. Review of existing studies

The construction of the new tunnel has been subject of a long lasting debate and several studies have been performed. In this section we summarize the main studies.

For every project that will potentially affect the environment an environmental impact report (EIR) is requested by the Flemish authorities. The effect of the OWV has been the subject of two such reports, the Plan-MER Masterplan Antwerpen, BAM (2005) assesses the impact of the broader "Masterplan" for Antwerp, which the OWV is part of, whereas Plan-MER Oosterweelverbinding, BAM(2007) concentrates on the OWV project itself.

In the first report (Plan-MER Masterplan Antwerpen) the OWV has been compared to an alternative tunnel that would lie next to the existing KEN. More interestingly, three different toll regimes have been considered (no toll, the proposed toll levels and half of the proposed toll levels). The report concludes that the best performing strategy is the one where the OWV is built with agreed toll levels. This conclusion is the result of a multi-criteria-analysis. There is, however, a lack of quantitative results; the conclusion is merely drawn on a qualitative basis and not on a monetized costs and benefits basis. Moreover, all strategies with OWV are combined with a ban on freight in the KEN and no scenario with tolling of the KEN is considered. Only the strategy that performed qualitatively best in the report has been subject of a monetized cost-benefit analysis (BAM (2004)). This cost benefit analysis compared the OWV project with the proposed toll level with the do-nothing scenario and concludes that the project has positive net benefits at a discount rate of 4%.

The second EIR report (Plan-MER Oosterweelverbinding, BAM(2007)) is focused on the OWV itself. After public criticism, other alternative trajectories of the OWV were incorporated in the analyses and more interestingly, more toll scenarios were included. To be more precise, three scenarios were compared: (1) proposed toll in OWV and ban on freight in KEN; (2) same toll on OWV and KEN for freight and passenger cars and (3) same toll for freight on KEN as on OWV. Again only very qualitative comparisons were made. The report concludes that the additional scenarios do not provide any added value. Again the argumentation is very qualitative and there is no cost-benefit study of the alternative tolling scenarios.

After those reports the public debate has largely been dominated by the precise trajectory of the tunnel. In 2009 an additional study compared three alternative trajectories (Arup-Sum (2009)). They find that each trajectory had its benefits and proposed yet another alternative trajectory. The role of correct pricing was mentioned as important but further analysis of other pricing schemes was not part of the task and thus disregarded.

In de Borger and Proost (2009), an attempt is made to redirect and broaden the discussion. They calibrate a very simple bottleneck model with two parallel links (KEN and Oosterweel) and homogeneous drivers to the Oosterweel data. They find that better use of the existing capacity by pricing of KEN merits serious analysis and could be a better alternative than the current Oosterweel proposal. Recently, another study group (Forum 2020) proposed an alternative plan with a stepwise investment plan for the broader Antwerp region. They stressed the importance of pricing in all scenarios.

3. The MOLINO-II model and its application to Antwerp

In this section we give a brief introduction to MOLINO-II and how it is applied to the case-study, for a detailed overview of the model features we refer to de Palma et. al. (2010).

3.1. Structure of the model

The MOLINO-II model was developed to assess transport pricing, investments and regulatory regimes with emphasis on the allocation of revenues from user charges. The model has been used in a variety of case studies that involve several modes (see Proost et al, 2010). Since the model has to be applicable to very diverse problems covering all kinds of modes, it is kept abstract and general.

The model is a multi-purpose model that allows assessing investments as well as strategic pricing behavior by operators in a simplified network. It is calibrated to an exogenous transport baseline that can be developed with any transport forecasting model. The time horizon, which can be chosen by the user, typically covers 10 to 50 years. MOLINO-II is a partial equilibrium model of the transport market: income levels of the private transport users, and production levels of the firms using freight services as input, are taken as given. The model includes separate modules for demand, supply, equilibrium, and the regulatory framework.

For each transport problem a simple network is defined with the main Origins and Destinations (OD). The OD's are connected via a network with links. Combination of links allows to define different paths for each OD. The model will determine what paths are used for each OD.

The total transport demand for each OD is determined in the demand module. The demand module for passenger transport features an aggregate nested CES utility function with three levels: choice between transport and consumption of a composite commodity, choice between peak and off-peak periods, and choice between the transport alternatives. Elasticities of substitution at each level are parametrically given. Passengers can be segmented into classes that differ with respect to their travel preferences, incomes and costs of travel time. The demand module for freight transport is based on an aggregate CES cost function (production levels are given) and also features three levels. The first level encompasses choice between transport and other production inputs, and the second and third levels are the same as for passenger transport.

Transport users of a given path pay the sum of the generalized costs of its links. The generalized cost of a link contains several components: a resource cost (say fuel for a car), taxes levied by central and local governments (say fuel taxes and car taxes), a user fee (toll or rail fare) and a time cost that will be a function of the relation between the total number of users and the available capacity.

For each transport alternative a distinction can be made between an operator who takes care of maintenance and can set tolls or user charges, and an infrastructure supplier who decides on capacity extensions and on infrastructure charges. The costs of the operator have a linear structure: a fixed cost, constant variable maintenance and operation costs that depend on the type of vehicle or load, and finally a payment for infrastructure use that can be specified in

different ways. The infrastructure provider also has a linear cost structure where the main costs are the investment and associated financial costs for the infrastructure. Operator and infrastructure suppliers can be private or public agents, and the cost level can depend on the contractual form.

The model includes a local and a central government that can pursue different objectives and control different tax and subsidy instruments including fuel taxes, public transport subsidies and profit taxes. Given the demand and cost functions the equilibrium module computes a fixed-point solution in terms of prices and levels of congestion for the transport alternatives. Primary outputs from MOLINO-II are equilibrium prices, transport volumes, travel times, cost efficiency of operations, toll revenues and financial balances, travellers' surplus and social welfare.

3.2. Application of the model to the Oosterweel case study

3.2.1. Users

The model allows specifying different types of passengers and freight users. For this case study we distinguish for passengers between commuters ("WORK") and non commuters ("OTHER"). They will differ in their values of time and in the ease that they can substitute between peak and off-peak periods. For freight we allow for three different types of freight: local, transit and harbor related traffic. The main distinction here is their route choice. Transit traffic ("TRANSIT") has an origin or a destination outside the Belgian borders⁴, local traffic ("LOCAL") is defined by having both origin and destination within the Belgian border but different from the harbor of Antwerp. Harbor traffic ("HARBOR") is traffic with origin or destination in the harbor of Antwerp.

3.2.2. The Network

A user travels from an origin to a destination and to do so he can choose between different paths. A path consists of a sequence of links, each link connecting two nodes. In the MOLINO-II model the network is deliberately kept simple, only the key links are considered. In the next sections we argue the choices made for the road and rail network.

3.2.2.1. Road

The OWV has several functions. The main goal of this new infrastructure is to alleviate traffic on the existing tunnel (the KEN) and on the southern part of the Ring road around Antwerp. It is therefore clear that these two segments must be incorporated in our network. At the moment two alternatives for the KEN already exist: the Waaslandtunnel (WLT) and the Liefkenshoek tunnel (LFK). The WLT is an old tunnel in the city center which has a very limited capacity and which is forbidden to freight, for these reasons we believe that this tunnel can not be a serious alternative. The LFK does have enough capacity but is now underused. Reasons for this are twofold; first the tunnel lies north of the city which considerably lengthens the journey for users heading southwards, and second this tunnel is tolled while the KEN is not. For users heading to the north or for traffic from or to the port of Antwerp this tunnel is, however, a good alternative so this link should be part of the considered network.

The simplified network:

⁴ The model producing the demand data only models Belgium and the Netherlands for road traffic. Traffic is considered as being transit when it has as origin or destination a zone at the border of Belgium or in the Netherlands.

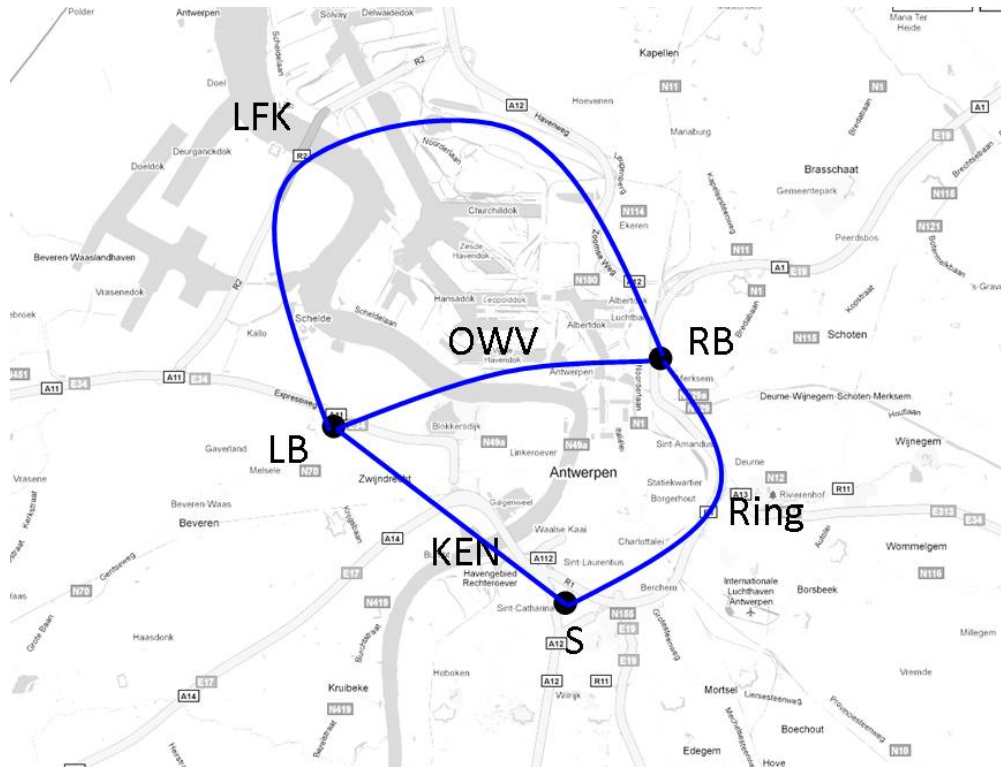

Figure 3-1: The road network

Traffic with origin “LB” (Left Bank) can be traffic coming from Gent or France via the E34 or E17 or can originate at the left bank of the port of Antwerp. These users can choose between two (or three in 2015 with the OWV) tunnels to cross the Scheldt. Traffic heading southwards (towards Mechelen and Brussels via the A12 or E19) will leave the network at the node “S”. The rest of the traffic heads to the North (Netherlands), East (Hasselt or Germany) or the right bank of the Port, this traffic has as destination “RB”.

We thus limit ourselves to traffic that crosses the Scheldt using the LFK, OWV or KEN or traffic that uses the southern part of the ring road. Since traffic flows are more or less symmetric we will only consider flows from West to East.

3.2.2.2. Rail

Due to a lack of consistent data rail is not taken as an option for passengers. Public transport (tram, bus ect.) is, however, taken into account in an indirect way since the expected data for road use when the tunnel has been built are generated by a model where public transport is part of the network.

The rail network for freight is given schematically in Figure 3-2:

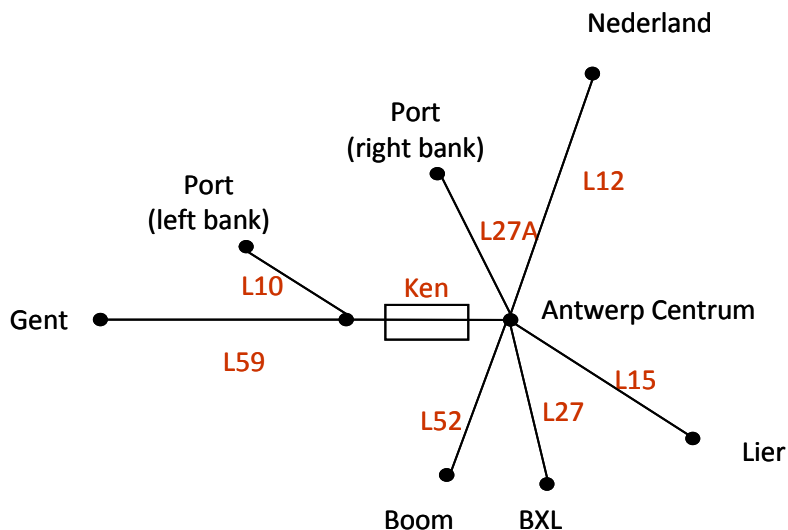

Figure 3-2: rail network

Again, we will simplify the network to a network with three nodes: “LB”, “S” and “RB” and only consider traffic that crosses the Scheldt from West to East. Traffic from the rail lines L59 and L10 will enter our network in LB. Freight with destination Brussels or France will use the KEN rail tunnel (KT) and leave the network in S via the lines L52, L27 or L15. Freight that uses the KEN rail tunnel can also continue to the north via the link T and leave the network at RB where it can head to the north (or east) via L12 or to the right bank of the harbor. The simplified road and rail networks are put together in Figure 3-3:

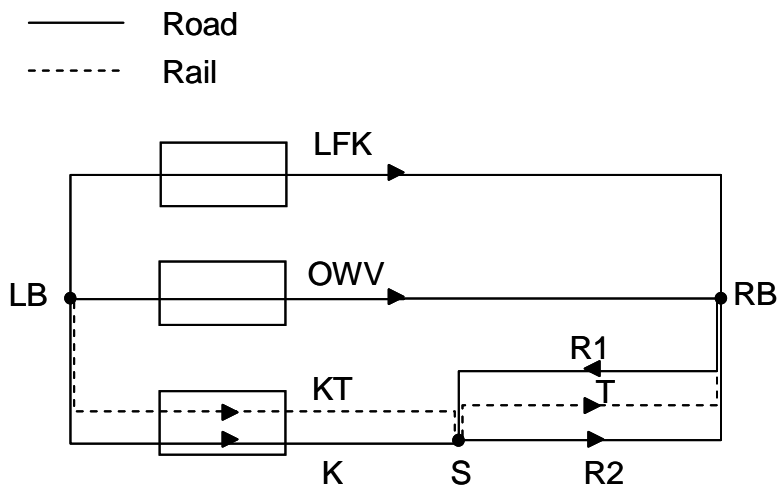

Figure 3-3: The MOLINO-II network

3.2.2.3. OD's, links and paths

Since we are only considering traffic flows from East to West and traffic on the ring road (R) we need four OD's : **LB-RB**, **LB-S**, **S-RB**, **RB-S**. Each origin of each OD is linked to the associated destination node by a path which consists out of one or more links. The network consists of seven links, namely:

LFK= Liefkenshoektunnel from LB to RB
 KEN = KEN from LB to RB
 OWV = Oosterweelverbinding from LB to RB
 R1 = ring from North to South
 R2 = ring from South to North
 KT = KENrailtunnel from LB to RB
 T = railway from S to RB

The paths of interest in this case study are given in the Table 3-1 and Table 3-2:

For passengers we have only paths consisting of road links:

OD:	LB-Z	LB-RB	S-RB	RB-S
Paths:	KEN	KEN, R2	R2	R1
	OWV, R1	OWV		
	LFK, R1	LFK		

Table 3-1: paths for passengers

For freight we have two modes, rail and road⁵:

OD:	LB-Z	LB-RB	S-RB	RB-S
Paths:	KEN, R2	KEN	R2	R1
	OWV	OWV, R1	T	
	LFK	LFK, R1		
	KT	KT, T		

Table 3-2: paths for freight

3.2.3. Agents

There are four different agents involved in the project, two public and two private agents. The two public agents are the Flemish government (which we call the local government) and the federal government (or central government); the two private players are the operators of the LFK and the operator of the new OWV. We do not consider the rail operators explicitly since we do not have enough data on the costs and on the charges of the rail network. This means that for the rail operators, the prices charged to the customers cover the marginal costs of the operators.

3.2.4. Scenarios

The following table summarizes the different scenarios analyzed:

	BAU	A1	A2	A3	A4	B0	B1	B2	B3
OWV	No	No	No	No	No	Yes	Yes	Yes	Yes
toll OWV	X	X	X	X	X	No	Yes	Yes	Yes
toll KEN	No	No	No	RR	Yes	No	No	No	Yes
toll LFK	Yes	Yes	No	Yes	Yes	Yes	Yes	Yes	Yes
Freight banned from KEN	FREE	BAN	FREE	FREE	FREE	FREE	FREE	BAN	FREE

Table 3-3: the scenarios

There are five scenarios without any new investment, these are (BAU) the business as usual scenario, where no new pricing nor investment is undertaken; (A1) refrain from building the new tunnel, but ban freight from the KEN to alleviate congestion in the KEN and on the ring road; (A2) set tolls equal to zero in the LFK to attract traffic into this underused tunnel; (A3) introduces a kilometercharge on the Belgian motorway network and keeps present tolling on LFK; (A4) to alleviate congestion in the KEN, tolls are now also charged on the KEN for passengers and trucks.

⁵ The MMA2+ model which generated the data used for calibrating MOLINO-II does not consider inland shipping, we were therefore limited in the modelling of freight to road and rail. Implicitly, the 2007 inland shipping volumes and their evolution is kept fixed and independent of the policy scenarios considered.

If the OWV is built, four possible scenarios are of interest: (B0) the OWV is built but remains untolled; (B1) the OWV is tolled as proposed but the KEN remains free for freight; (B2) the proposal is applied in its entirety (tolls on OWV and ban on freight in the KEN); (B3) instead of a ban, the use of the KEN is tolled for trucks and cars.

It is assumed that all changes to the BAU scenario in terms of tolls and capacity start from 2015 onwards. In this way there is enough time to prepare the implementation of new toll systems and to build a new bridge. All scenarios are assessed for the period 2015-2030.

In the scenarios the better use of the LFK is given a prominent role and we assume in this study that tolls can be freely varied on this tunnel. This requires some justification. The LFK tunnel was originally a privately financed project where the tolls were supposed to cover its costs. In the meantime, the tunnel has become public property and there may still be short term commitments in terms of toll revenues. We assume that from 2015 onwards, there are no commitments to the private sector anymore and the tolls can be freely chosen by the government.

3.2.5. Welfare

One of the outputs MOLINO-II provides is the welfare. For this case study we define the welfare as the sum of the users' surplus and the toll revenues on the different links, minus the external costs (except congestion), the operation costs and the investment cost. In this paper we give equal weights to variations in government income, toll revenues and consumer surplus. It is possible to give a premium to government income (the marginal cost of public funds approach, see Calthrop et al.(2010)). This is not done yet as the financial construction to finance the investment is not yet clear. The premium for government revenues may also be important if there is a global financial constraint for all investments in the Antwerp region. Also this financial constraint is not clearly defined.

We will consider three different welfare functions: Domestic, Total and Simple. The "Domestic" welfare disregards the changes in utility of the transit freight while the welfare function "Total" sets them on equal footing as the local surpluses. For the "Simple" welfare we did not take into account the changes in tax revenues nor the changes in external costs since it can be argued that the diverted traffic will use other parts of the Belgian network and will generate taxes and external costs on the part of the network that is not explicitly modelled.

4. Data and Calibration

4.1. Demand data: current and expected

The demand data are produced by the MMA2 model of the Traffic Centre of Flanders ("Verkeerscentrum Vlaanderen"). This model contains a far more detailed network than MOLINO-II but has several drawbacks: it only models an average peak hour and total demand volume is inelastic; congestion in the peak will only lead to a change in route choice, there is no possibility to change the departure time.

The data we used are so called "selected link analyses" (SLA's) on the different links of the network. These SLA's tell us how many passenger vehicles, light trucks (<3.5 tons) and heavy trucks use a specific link and what their origin and destinations are. The model divides Belgium and the Netherlands in 3320 zones. Data are available for an average morning peak hour (8h) or evening peak hour (17h) in 2007 and 2020. In 2020 it is assumed that the whole Masterplan-Antwerpen is operational. This means that in 2020 the OWV is built and tolled at the levels set by the BAM and that freight is not allowed to use the KEN.

For rail traffic only the data for freight were useful to us. In this dataset the whole of Europe is modeled. The SLA's give us the yearly tonnage on each link and are available for 2004 and 2020.

To convert these data into data that can be fed into MOLINO-II some assumptions had to be made (see Appendix A for MMA data and assumptions). Table A-1 and Table A-2 report the demand data for 2007 and 2020 in veh per day per user type per period of day for every path.

4.2. Generalized Prices

Users will base their decisions on the generalised cost of a trip. These costs comprise a monetary term and a time cost. The monetary term has four components: (i) the resource costs (rc) which includes the netto purchasing price of the vehicle, the insurance costs, the maintenance costs and the fuel costs (all excl taxes)); (ii) taxes paid to the federal government ($tax(fed)$) which consists of the the purchase tax, the car ownership levy and fuel tax; (iii) taxes paid to the Flemish government such as the first registration tax, traffic tax and the eurovignet and (iv) the toll.

The resource costs and taxes are reported in the following table (for more details, see Appendix B):

	Passenger car	Freight	Rail
rc	0.16	0.28	32.45
tax (fed)	0.08	0.10	0
tax (fl)	0.02	0.02	0

Table 4-1: resource costs and taxes in euro/vehkm

the toll levels used for the LFK and the OWV are (for more details see Appendix B):

	WORK	LEISURE	FREIGHT
LFK	3.2	4.4	13
OWV	2.4	2.4	13

Table 4-2: tolls in euro/veh

The second component of the generalised price is the time cost which is the value of time of a user (VOT) times the time needed to accomplish the trip (tt). In this case study we assume that the travel time is a linear function of the traffic flows⁶. The travel time is defined by the speed-flow relation:

$$tt = \frac{l}{v^{\max}} \left[1 + \alpha \left(\frac{q}{cap} \right) \right]$$

where l is the length of the link, v^{\max} is the maximum speed on the link and q is the number of PCE per hour on the link. The parameters α is equal to one for road links and zero for rail links (we assume that on rail links there is no congestion). The parameters cap is chosen to fit the existing speed-flow data for each link⁷.

4.3. Other costs

4.3.1. Operation, Maintenance and Investment costs

The investment costs for the new crossing are, according to BAM (2004), estimated to be €1.344 billion for the tunnel itself and €2.25 billion for the project as a whole . These costs are spread in time and the total discounted investment cost for the tunnel amounts to

⁶ This the subject of many debates in the traffic literature, see Small & Verhoef (2007). As we use a rather macro model, we prefer to use a linear average time cost function. Such a function is consistent with a bottleneck interpretation of congestion where consumers trade-off schedule delay and queuing costs (see Arnott et. al. (1993)).

⁷ For the values of the parameters of the speed-flow relation we refer to Appendix B and C.

€1.083 billion⁸. The lifetime of the investment is 55 years and the discounted salvage value is €234 million.

The operation and maintenance costs per year are estimated at 1.5% of the investment cost or approximately €20 million per year (BAM(2004)).

4.3.2. External costs and other data

The external congestion costs are included in the generalised costs, the other external costs are the environmental, noise and accident costs. We use the estimates of the TREMOVE model (De Ceuster et. al. (2005)). In [veh/km] these are:

	Passenger car	Freight
Road	0.11	0.36
Rail		4.41

Table 4-3: external costs (source: TREMOVE)

To calibrate the nested CES functions of the MOLINO-II model one needs two more inputs; for each level we need to specify the elasticity of substitution and we need to give the share of income (or total production costs for freight) that is dedicated to transport.

a) Elasticity of Substitution

	WORK	LEISURE	FREIGHT
transport/other	0,2	0,2	0,2
periods	0.9	2	2
paths	7	7	7

Table 4-4: Elasticities of substitution

b) Share of transport expenditures in total consumption

PAS	FREIGHT
5%	10%

4.4. Calibration

For the calibration of the MOLINO model we have two reference points: the “observed” 2007 data (as reported in Table A-1) and the “official” forecast for the transport flows in 2020 in the presence of the new OWV tunnel and with a ban on freight in the KEN (given in Table A-2). The model parameters are calibrated with the OWV in such a way that the model reproduces in a satisfactory way the 2007 data without OWV.

	WORK		LEISURE		LOCAL		TRANSIT		HARBOR	
	Peak	OffPeak	Peak	OffPeak	Peak	OffPeak	Peak	OffPeak	Peak	OffPeak
KEN	17800	7600	10889	12279	14442	51203	513	1819	2229	7902
OWV,R1	5	5	5	5	5	5	5	5	5	5
LFK,R1	1	1	1	1	1	1	1	1	1	1
KT	1	1	1	1	359	1274	10	10	383	1359
KEN,R2	9450	4000	5850	6800	30000	111000	8500	34645	24000	91000
OWV	2491	1074	1527	1733	4861	16624	1064	3640	2858	9775
LFK	3000	1100	1800	2000	2500	9000	900	3000	15000	55000
KT,T	1	1	1	1	505	1790	230	816	1134	4021
R2	40227	17240	24655	27803	36229	128448	1150	4077	8344	29584
T	1	1	1	1	543	1925	298	1056	5469	19389
R1	45684	19579	28000	31574	80914	286876	2568	9105	18636	66073

Table 4-5: demand data 2007 used for calibration in pas or ton/day

⁸ In BAM (2004) it is assumed that the tunnel will be operational in 2010. since this is obviously not the case we delayed all investments and thus costs by five years. We assume a discount rate of 4% as in BAM (2004).

	WORK		LEISURE		LOCAL		TRANSIT		HARBOR	
	Peak	OffPeak	Peak	OffPeak	Peak	OffPeak	Peak	OffPeak	Peak	OffPeak
KEN	17772	7623	10871	12317	14271	51114	531	1854	2185	7813
OWV,R1	0	0	0	0	0	0	0	0	0	0
LFK,R1	1	1	1	1	1	1	1	1	1	1
KT	1	1	1	1	7	24	0	0	7	26
KEN,R2	11422	4954	7078	8303	36750	137988	9827	40321	25235	96661
OWV	0	0	0	0	0	0	0	0	0	0
LFK	3743	1397	2235	2490	3259	11784	1107	3678	16783	61534
KT,T	1	1	1	1	12	42	5	18	23	80
R2	40146	17239	24590	27820	35949	128290	1123	4016	8025	28785
T	1	1	1	1	10	36	6	19	100	350
R1	45684	19579	28000	31574	80916	286874	2568	9105	18637	66073

Table 4-6: Simulation results for 2007 when OWV is made unavailable in pas or ton/day

5. Simulation results

For the simulations we use a time horizon of 23 years starting in 2007. If the new tunnel is built, it is assumed to become available in 2015 and a salvage value is computed at the end of the horizon in 2030. An annual social discount rate of 4% is used to compute present values⁹. We assume an exogenous demand growth of 1% per year. The outputs generated by MOLINO-II that are of interest to us are first of all the demand in 2030 and the corresponding generalized costs, the toll and tax revenues on the different links and the welfare of the different user classes.

The simulation results are summarized in Table 5-1. The first four rows summarize the scenarios, the next twelve rows give the changes in traffic flows (in [veh/day]) compared to the BAU (remember that we focus on the West to East flows). The rest of the table are the discounted sums of the different welfare components. The changes in time costs and generalised costs are reported in Table D-1 and Table D-2 in Appendix D.

Scenarios	Name	BAU	A1	A2	A3	A4	B0	B1	B2	B3
	OWV	No	No	No	No	No	Yes	Yes	Yes	Yes
	Toll regime	LFK	LFK	No	RR LFK	LFK KEN	LFK	OWV LFK	OWV LFK	OWV LFK KEN
	Freight ban	FREE	BAN	FREE	FREE	FREE	FREE	FREE	BAN	FREE

Passenger cars [veh/day]

KEN	50413	2768	-16707	465	-17947	-15049	-3478	-1205	-20555
OWV	0	0	0	0	0	25974	4303	3759	9719
LFK	6201	-1358	13944	-235	12280	-4978	-1232	-1959	6546
R1 (RB → S)	78474	-1	26	7	78	71	12	6	336
R2 (S → RB)	88887	2853	-16381	510	-15508	-14563	-3384	-1058	-17254

Freight [veh/day] or [railcontainers/day]

KEN	30344	-30344	-21245	-4884	-21514	-23230	-3242	-30344	-25404
OWV	0	0	0	0	0	33637	2791	9536	18904
LFK	7061	14546	16979	2112	14993	-6665	-925	6361	2146
R1 (RB → S)	33346	22	4	-622	13	40	2	85	149
R2 (S → RB)	39558	-24032	-20639	-5746	-19670	-22462	-3138	-23993	-23155
KT	1029	10800	-800	514	171	-857	-171	8114	-114
T	2914	2971	-1257	1143	-1086	-1257	-229	571	-1314

Utilities and Production costs [Milj euro]

⁹ A four percent annual discount rate is used in the cost benefit analysis performed by BAM (2004)

WORK		25	108	4	24	100	16	38	62
OTHER		14	132	4	56	90	12	24	74
LOCAL		-358	260	-184	100	396	38	-194	308
TRANSIT		-85	70	-20	32	100	8	-48	84
HARBOR		-142	460	-66	306	392	22	-92	404
Tax revenues [Milj euro]									
Local	356	-12	-6	270	-10	-6	-4	-16	-14
Central	1544	-60	-30	-20	-46	-32	-18	-76	-66
Toll revenues [Milj euro]									
OWV	0	0	0	0	0	0	190	536	172
LFK	796	742	-466	110	-106	-430	-68	302	-298
KEN	0	0	0	0	146	0	0	0	110
Other costs [Milj euro]									
External costs	-3460	202	90	68	130	112	52	252	194
INV OWV	0	0	0	0	0	1083	1083	1083	1083
Salvage Value	0	0	0	0	0	234	234	234	234
OPC OWV	0	0	0	0	0	162	162	162	162
Welfare									
Domestic	0	412	548	186	600	-389	-771	-236	-62
Total	0	327	618	166	632	-289	-763	-285	22
Simple	0	196	564	122	558	-363	-793	-445	-92

Table 5-1: Simulation results

5.1. Scenario A1: no OWV, freight is banned from KEN

Freight road traffic going east or north is forced to use the LFK. The absence of trucks in the KEN implies an improvement in traffic conditions for passenger cars in the tunnel. This improvement leads to an increase of passenger cars in the KEN. Freight traffic heading south will either switch to rail or will choose another route outside of our network, which explains the reduction of total freight traffic that crosses the Scheldt (-15%). The time costs in the KEN improves while those in the LFK deteriorate. There is also a strong increase in rail use.

From a transport economic point of view the welfare increase can be explained. In the original situation one has a tolled (LFK) and an untolled alternative (the KEN). It is well known that in such a framework, the untolled alternative will have inefficiently high traffic flows while the tolled alternative will be underutilised. A policy that forces part of the traffic to use the tolled alternative can therefore be welfare improving.

Freight transport is now forced to change its routes and to pay toll. For all routes West-South, the ban on trucks in the KEN implies an important cost increase as the LFK route is much longer. The main beneficiaries are passenger transport that experiences less congestion in the KEN and the toll revenues. Overall there is a discounted "total" welfare gain of 327 Mio €.

5.2. Scenario A2: no OWV, no tolling on LFK

In order to increase the use of the LFK, one can either force freight to use the tunnel (A1) or make the tunnel toll free. So in this scenario all tolls on the LFK are abolished for freight and for passengers.

The biggest changes occur for traffic having RB as destination, for this traffic LFK now becomes much more attractive and there is a large shift in traffic from the KEN to the LFK and also from rail to road for freight. Due to the decrease in the use of the KEN and the part of the Ring South to East (R2) there will be a small increase of the use of the KEN for traffic heading south and more traffic will use the ring road to travel from S to RB. Compared to scenario A1 the traffic intensity in the LFK is higher but this is partly due to a modal shift from rail to road.

The utility of all users increases since the absence of toll will reduce their generalized prices. The loss in toll revenue is largely compensated by the increase in consumer surplus for passengers as

well as for freight; the largest gains are for the harbor related traffic. The reduction in external costs is mainly due to the reduction in traffic. There is a clear welfare gain compared to BAU but the LFK will see its revenues drop to zero from 2015 onwards.

This scenario performs much better than a ban for trucks on the KEN. There is now a discounted welfare gain of 618 million €. The main reasons are first that trucks heading South are no longer forced to take the detour via the LFK. Second, also the pricing of cars is more balanced and more cars use the LFK and this also means a congestion relief on the Ring Road.

5.3. Scenario A3: no OWV, kilometer charge

There is a kilometer charge on the motorways in Belgium for freight. This is modeled by introducing an increase in resource costs for trucks on the links that are part of the Belgian motorway network, being the KEN and the Ring road. Since there is already a toll on the LFK we assume that on this link the kilometer charge is not applied. As level for the kilometer charge we take figures from the TML study (De Ceuster et. al. (2009)). In this study they analyze the effects of different kilometer charges. In total nine schemes are analyzed, the cost of a vehkm increases between 0 and 25.5% depending on which scheme is chosen. In scenario A3 we will assume that the cost per km will increase by 25% for freight on the KEN and the ringroad. The toll on the LFK is kept at the present level.

The effects of the kilometer charge is minimal, there is a small reduction in overall traffic which leads to a small reduction of congestion in the KEN. There is a small increase in total discounted welfare of 166 million €.

5.4. Scenario A4: no OWV, tolling of the KEN and LFK

In this scenario we want to check whether a toll on the KEN could solve part of the mobility problems around Antwerp without having to invest in a new expensive infrastructure. We looked into the welfare effects of several toll combinations. We report here results for the following toll structure that is not necessarily optimal:.

	KEN	LFK
Passenger cars	0.6	1
Freight	1.925	3.15

Table 5-2: Tolls simulated [euro/veh]

These tolls are much lower than the current tolls on the LFK and this is logical. When car and truck use on both tunnels can be tolled, there is a much better use of current capacity, congestion levels decrease and the overall toll levels can be much lower. This scenario performs best in welfare terms because all traffic is tolled at a balanced level so that route choice is more in line with the social costs. Discounted welfare increases by 632 million €.

5.5. Scenario B0: OWV, no tolling on OWV

This first scenario has only tolls on the LFK and let users freely choose their preferred tunnel to cross the Scheldt. There is no ban on trucks for the KEN. It can be compared with scenario A1 but now there is an extra crossing. There is less congestion so more users cross the Scheldt. There is a clear shift from the KEN and the LFK to the OWV. The LFK is almost not used anymore. Another interesting result is the decrease in traffic on the Ringroad. Congestion is improved but this improved situation causes a modal shift from rail to road.

Compared to the BAU scenario the surplus of all the users (freight and passengers) increases. We have a decrease in tax revenues due to a decrease in total kilometers' driven.

Overall users' surplus increases strongly but this insufficient to compensate the loss in toll revenues of the LFK and the large investment cost of the OWV. Net discounted welfare decreases by 289 million € compared to the BAU scenario.

5.6. Scenario B1: OWV tolled

Due to the toll on the OWV, the switch to the new tunnel seen in scenario B0 is less important and the decrease in time costs on the KEN is smaller. The gain in surplus for the freight traffic will also be considerably less. There is an increase in toll revenues on OWV but overall welfare decreases even more than in the first scenario because truck traffic is using too much the KEN. This is the worst scenario of all: one makes large investments in capacity but the tolling makes sure all tunnel capacities are badly used. The total discounted welfare decreases by 763 million €.

5.7. Scenario B2: OWV tolled and freight banned from KEN

This is the official BAM scenario. It has tolls for trucks and cars on LFK and on OWV plus a ban for trucks on the KEN. Since the total cost for a trip crossing the Scheldt will considerably increase for freight we have an important reduction in freight traffic. They see their costs increase by 334 million €. Comparing across all alternatives, this is the second worst outcome (after scenario A1 that also includes a ban for KEN but offers only a tolled LFK). The cars are net beneficiaries.

In terms of overall welfare, the scenario with a ban on trucks in the KEN performs better than the previous scenario. As in the case of scenario A1, the ban on the KEN for trucks reduces the overall use of the KEN so that the overall use of the three tunnels is more balanced and uses capacities better. The major disadvantages that remain are that passenger cars still face the wrong pricing and the trucks going South are forced to make a large detour. The overall welfare outcome of this scenario is -285 million €. This means that the investment in the OWV is not justified under these conditions.

5.8. Scenario B3: OWV, LFK and KEN tolled

As in scenario A4 it is not easy to determine the welfare maximising tolls. Here we report first results for the following tolls:

	KEN	OWV	LFK
Passenger cas	0.6	0.6	1
Freight	1.925	1.925	3.15

As can be seen the tolls that are simulated are much lower than the present tolls in the LFK and than the tolls planned for the OWV. The logic is again that all traffic is charged and capacity has been increased so tolls need to be lower if we want them to be closer to the marginal social cost.

Lower tolls but applied to all tunnels, in combination with the absence of a ban on trucks in the KEN, generate the best welfare result in the presence of the OWV. The surplus of car users and of truck users increases because they all have more choice options at relatively low tolls. Total toll revenues for the three tunnels are more or less equal to the toll revenues in the reference scenario where only the LFK is tolled. Overall welfare is slightly positive: +22 million €. This is a meager welfare outcome for an investment of 1,085 million €. The slightest unforeseen increase in investment costs will make also the welfare outcome of this scenario negative.

Once one tolls all tunnels, one can easily increase the overall toll level and generate more toll revenues. This will generate some welfare losses if tolls exceed the marginal external congestion costs but this is the best way to meet revenue constraints.

6. Conclusions

In this paper we have analyzed alternative pricing and tolling scenarios for the case where the foreseen Oosterweeljunction is build and is not build.

We start with a reference scenario where the existing capacity is not efficiently used because one tunnel (LFK) is tolled and the other (KEN) is not.

The tolling scenarios that manage to improve the use of the existing tunnel capacities perform best in overall welfare terms. A simple scenario that abolishes the tolls on the use of the LFK can generate an

important welfare gain of more than 600 discounted million €. More complex scenarios can do better and there also exist scenarios that increase welfare and increase overall toll revenues.

The scenarios with Oosterweelbridge generate in general a negative welfare outcome. The only scenario that generates a small welfare increase is a scenario that contains relatively low tolls on all the three tunnels. The main reason why the Oosterweelbridge performs not well in welfare terms is that by using better the existing capacity, one avoids important investment costs. Whenever, as is the case with most investment projects, the investment cost turns out to be larger than foreseen, our conclusion is re-enforced.

There are several proviso's for our analysis. First we only analysed a limited number of scenarios for which sufficient information was available. There are certainly many transport management measures other than pricing that can be studied and can improve the existing capacity. The same holds for broader road investment plans like the ones studied by FORUM 2020. These merit further study as our analysis was limited to macro scale measures for which information was available.

Second, our model is simple and like all models too simple. It is a calibrated model on the basis of some observations but uses also computations with another model. It has to be considered as a sophisticated calculator to explore other options. When these options are revealed interesting they merit further study.

7. References

Arnott R., de Palma A., Lindsey R. (1993), "A structural model of peak period congestion: a traffic bottleneck with elastic demand", *American Economic review* 83, 161-179

BAM (2004) "MASTERPLAN ANTWERPEN – Maatschappelijke kosten-batenanalyse van de weg- en openbaarvervoersprojecten", eindrapport.

BAM (2005), "Plan-MER – mastreplan Antwerpen", eindrapport.

BAM (2007), "Plan-MER – Oosterweelverbinding", eindrapport

Calthrop, E., De Borger, B., Proost, S. (2010). Cost-benefit analysis of transport investments in distorted economies. *Transportation Research B, Methodological*, forthcoming

De Ceuster G. (2004), "Internalisering van externe kosten van wegverkeer in Vlaanderen", TMLLeuven.

De Ceuster G., Ivanova O. , Dunkerley F. and Proost S. (2005), Deliverable 3: "Computing revenues from pricing and possible financing gaps", *Funding Infrastructure: Guidelines for Europe, FUNDING - Sixth Framework programme*.

De Ceuster, G., Yperman I., C. Heyndrickx , F. Vanhove ,K. Vanherle, S. Proost, " Effecten van een kilometerheffing voor vrachtwagens" eindeverslag van studie voor Steunpunt fiscaliteit en begroting, Vlaamse Overheid, http://www.tmleuven.be/project/kmheffing/kmheffing_impact.pdf

de Palma A., Proost S., van der Loo S. (2010), "Assessing transport investments - towards a multi-purpose tool", *Transportation Research Part B Methodological*, Forthcoming.

Delhaye E., De Ceuster G., Vanherle K., Breemers T., Proost S. , Chen M., Van Meijeren J., Groen T., Snelders M., (2009), *Social cost-benefit analysis Iron Rhine*, commissioned by Infrabel, TML-TNO, http://www.tmleuven.be/project/ijzerenrijn/Report_SCBA_Iron_Rhine_v13022009b.pdf

De Ceuster, G., I. Yperman , C. Heyndrickx , F. Vanhove ,K. Vanherle, S. Proost, " Effecten van een kilometerheffing voor vrachtwagens" eindeverslag van studie voor Steunpunt fiscaliteit en begroting, Vlaamse Overheid, http://www.tmleuven.be/project/kmheffing/kmheffing_impact.pdf

ECSA B.V.B.A (2005), *Economische Ontwikkelingsstudie (EOS) voor de haven van Antwerpen – Eindrapport*.

Forum 2020, (2010) "Memorandum van het Forum 2020 voor een duurzame mobiliteit in en rond Antwerpen".

Proost S., Meire E., Knockaert J., (2004). Hervorming transportfiscaliteit in Vlaanderen.

Proost S., Dunkerley F., Van der Loo S., Adler N., Bröcker J., Korzhenevych A., (2010) "Do the selected Trans European transport investments pass the Cost Benefit test?", Discussion Paper CES , <http://www.econ.kuleuven.be/eng/ew/discussionpapers/Dps10/DPS1002.pdf>

A. Quantities

Data from MMA2 model:

Road traffic between 17h-18h in 2007 (veh/h)

	Passengers	LOCAL	TRANSIT	HARBOR
LB-S				
KEN	2865.58	164.91	5.86	25.45
OWV,R1	N	N	N	N
LFK,R1	0	0	0	0
LB-RB				
KEN,R2	1755.54	390.14	115.67	300.92
OWV	N	N	N	N
LFK	525.42	31.41	10.70	189.51
S-RB				
R2	6488.18	413.69	13.13	95.28
RB-S				
R1	7368.31	923.94	29.32	212.80

Source: computations on basis of data of Verkeerscentrum Vlaanderen

- Rail traffic in 2004 (ton/jaar)

	LOCAL	TRANSIT	HARBOR
LB-S			
KT	408,174.20	0	435,662.36
LB-RB			
KT,T	573,761.76	261,680.14	1,288,915.26
S-RB			
T	616,973.08	338,542.01	6,214,317.84

Source: computations on basis of data of Verkeerscentrum Vlaanderen

Road traffic between 17h-18h in 2020 (veh/h)

	Passengers	LBCAL	TRANSIT	HARBOR
LB-S				
KEN	4969.03	0	0	0
OWV,R1	25.03	75.3	0.16	73.35
LFK,R1	1.05	0	0	13.92
LB-RB				
KEN,R2	2011.55	0	0	0
OWV	651.1	652.86	118.95	300.68
LFK	1065.93	65.09	19.23	448.77
S-RB				
R2	3681.34	697.75	109.51	229.63
RB-S				
R1	4656.37	436.41	68.49	143.62

Source: computations on basis of data of Verkeerscentrum Vlaanderen

- Rail traffic in 2020 (ton/jaar)

	LOCAL	TRANSIT	HARBOR
LB-S			
KT	413594	0	1371676

LB-RB			
KT,T	231113	254350	987540
S-RB			
T	645568	470076	6651024

Source: computations on basis of data of Verkeerscentrum Vlaanderen

These need to be converted into passengers (or tons) per peak period and off-peak period.

Data needed for conversion:

Type				dimensions	Source
duration		peak	5	hours/day	BAM(2004) & Proost et.al. (2004)
		off-peak	19		
peak/off-peak share	work	peak	70	%	Proost et.al. (2004), WORK= personal estimate
		off-peak	30		
	leisure	peak	47		
		off-peak	53		
	Freight	peak	22		
		off-peak	78		
share work/leisure during peak	work		62	%	BAM(2004)
	leisure		38		
Occupancy	Passenger		2	pas/veh	PW= personal estimate, Freight = ECSA (2005), Rail= SBA Iron Rhine (Delhaye at al.)
	Freight		17.5	ton/veh	
	Rail		1000	ton/train	
days/year			250	days/year	EOS

Resulting demand data are:

	WORK		LEISURE		LOCAL		TRANSIT		HARBOR	
	Peak	OffPeak	Peak	OffPeak	Peak	OffPeak	Peak	OffPeak	Peak	OffPeak
LB-S										
KEN	8884	3807	5445	6140	825	2926	29	104	127	452
OWV,R1	NA	NA	NA	NA	NA	NA	NA	NA	NA	NA
LFK,R1	1	1	1	1	0	0	0	0	0	0
KT	NA	NA	NA	NA	0	1	0	0	0	1
LB-RB										
KEN,R2	5442	2333	3336	3762	1952	6922	579	2052	1506	5339
OWV	NA	NA	NA	NA	NA	NA	NA	NA	NA	NA
LFK	1629	698	999	1126	157	557	54	190	948	3362
KT,T	NA	NA	NA	NA	1	2	0	1	1	4
S-RB										
R2	20114	8620	12328	13902	2070	7340	66	233	477	1691
T	NA	NA	NA	NA	1	2	0	1	5	19
RB-S										
R1	22842	9790	14000	15787	4624	16393	147	520	1065	3776

Table A-1: Demand data for 2007 in veh/day, where NA stands for Not Available

	WORK		LEISURE		LOCAL		TRANSIT		HARBOR	
	Peak	OffPeak	Peak	OffPeak	Peak	OffPeak	Peak	OffPeak	Peak	OffPeak
LB-S										
KEN	15404	6602	9441	10646	0	0	0	0	0	0
OWV,R1	78	33	48	54	377	1336	1	3	367	1301
LFK,R1	3	1	2	2	0	0	0	0	70	265
KT	NA	NA	NA	NA	21	74	0	0	69	244
LB-RB										
KEN,R2	6236	2672	3822	4310	0	0	0	0	0	0
OWV	2018	865	1237	1395	3267	11583	595	2110	1505	5335
LFK	3304	1416	2025	2284	326	1155	96	341	2246	7962
KT,T	NA	NA	NA	NA	12	41	13	45	49	175
S-RB										
R2	11412	4891	6995	7887	3492	12380	548	1943	1149	4074
T	NA	NA	NA	NA	32	115	24	84	334	1186
RB-S										
R1	14435	6186	8847	9977	2184	7743	343	1215	719	2548

Table A-2: Demand data for 2020 in veh/day, where NA stands for Not Available

B. Generalized prices

The values used are:

		Passenger cars	FREIGHT	dimension	Source
resource costs	benzine	0.11		euro/vkm	De Ceuster (2004)
	diesel	0.18	0.33		
federal tx	benzine	0.01		euro/km	
	diesel	0.059	0.119		
local tax	benzine	0.021		euro/km	
	diesel	0.012	0.022		
share	benzine	68	0	%	BAM(2004)
	diesel	32	100		

source: De Ceuster e.a. (2004)

figures in De Ceuster e.a . are from 2002, these are corrected and converted to € 2004

This gives us for road [euro/vehkm]:

	Passenger car	FREIGHT
rc	0.16	0.28
tax (fed)	0.08	0.10
tax (fl)	0.02	0.02

resource cost and taxes for rail [€/vehkm] are

	RAIL
rc	32.45
tax (fed)	0
tax (fl)	0

source: Resource cost REMOVE (All countries)

The tolls on LFK found on the website are [€ 2009/veh] :

LFK	PW	FREIGHT incl btw	FREIGHT excl btw
Manueel	5.5	18	14.88
Tele tol	3.23	12.88	10.64
credit card	4.5	16	13.22

Source: website Liefkenshoektunnel

We assume that commuters all pay the cheapest toll (Tele Tol), while for Leisure and freight, we take an average toll. This gives us following toll levels

toll levels in [€/veh]

	WORK	LEISURE	FREIGHT
LFK	3.2	4.4	13
OWV	2.4	2.4	13

Note: We assume that VAT is paid by passengers but that freight do not pay VAT.

Data needed to compute the time costs:

Type			dimension	Source
VOT	work	8.51	€/veh-h	BAM (2004)
	leisure	5.3		
	freight	38.42		
PCE	Passenger cars	1		BAM (2004)
	Freight (road)	2.5		

	KEN	OWV	LFK	Ring	KT	T	
length	5.6	10	14	8	5.6	8	km
max speed	100	100	100	100	250	250	km/h
cap	13000	13000	8500	17500	N	N	
beta	1	1	1	1	N	N	
alpha	1	1	1	1	0	0	

Source: Auhors' calculation

The length of the links LFK and R are based on the average length of a trip from LB to RO using the LFK or KEN and R respectively (see C).

The speed-flow relations are taken to be linear in the traffic volumes (beta equal to one). To calibrate the function we used observed quantities and speeds on the links of interest as given by the Traffic centrum of flanders, for the OWV we assume that it has the same capacity as the KEN.

C. Lengths of links

Vehicles using the KEN and have as destination "RB" can leave the ring road at three different locations: they can leave at the exits "East", "North" or "Harbor" (see Figure C-1 for location of exits). The proportion of vehicles leaving at the different exits and the total length of their trip is given in following table:

	Vehicles [%]	trip length [km]
East	58	10
North	36	16.1
Harbor	7	29.4

Source: Verkeerscentrum Vlaanderen and Authors' calculation

The path length of the path (KEN, R) is thus a weighted average of these different lengths which is 13.56 km. Knowing that the KEN is 5.6km long, this gives us the length of the link R, namely 8 km. To compute the length of the link LFK we follow the same procedure. Vehicles using the path LFK to go from the origin “LB” to the destination node “RB” leave the ringroad at two different exits “Harbor” or “North” (according to the data no vehicle using the LFK tunnel exits the Ring road at “East” or “South”):

	Vehicles [%]	trip length [km]
Harbor	91	13
North	9	23

Source: Verkeerscentrum Vlaanderen and Authors' calculation

The average length is thus approximately 14km for the link LFK.

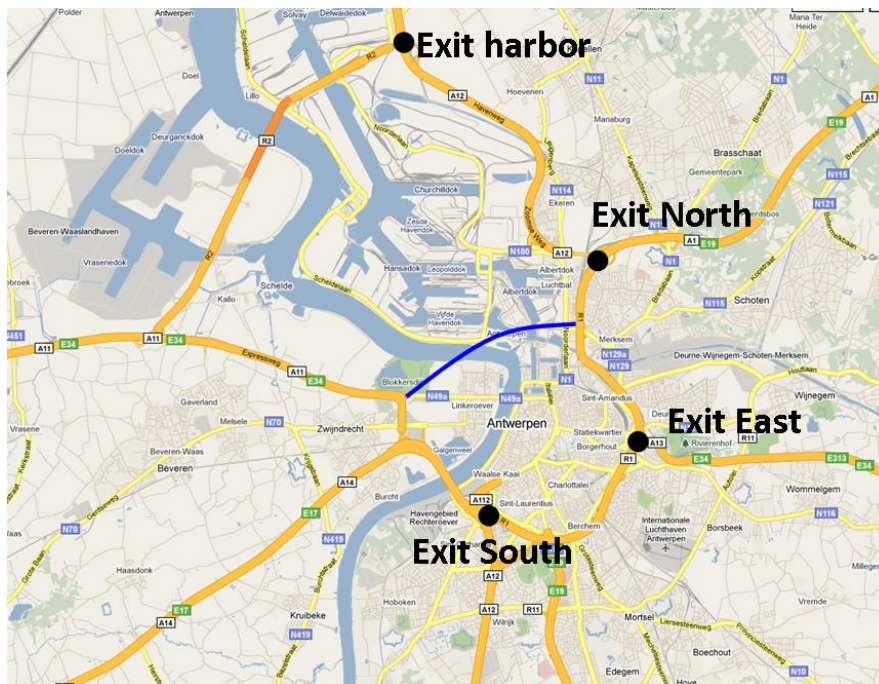

Figure C-1: Location of exits

D. Changes in time costs and generalised prices

Scenarios	Name		BAU		A1		A2		A3		A4		B0		B1		B2		B3	
	OWV		No		No		No		No		No		Yes		Yes		Yes		Yes	
	Toll regime		LFK		LFK		No		RR LFK		KEN LFK		LFK		OWV LFK		OWV LFK		OWV LFK KEN	
	Freightban		FREE		BAN		FREE		FREE		FREE		FREE		FREE		BAN		FREE	
		Peak	Off-P	Peak	Off-P	Peak	Off-P	Peak	Off-P	Peak	Off-P	Peak	Off-P	Peak	Off-P	Peak	Off-P	Peak	Off-P	

WORK [euro/veh]

KEN	0.809	0.632	-0.105	-0.113	-0.142	-0.097	-0.014	-0.019	-0.144	-0.100	-0.146	-0.103	-0.025	-0.016	-0.120	-0.116	-0.176	-0.116
OWV	N	N	N	N	N	N	N	N	N	N	1.264	1.120	0.904	0.875	0.951	0.918	1.066	0.989
LFK	1.401	1.310	0.210	0.203	0.444	0.299	0.027	0.030	0.394	0.263	-0.181	-0.112	-0.034	-0.017	0.067	0.082	0.126	0.055
R2	1.248	0.914	-0.086	-0.094	-0.146	-0.101	-0.017	-0.024	-0.136	-0.096	-0.148	-0.106	-0.026	-0.016	-0.101	-0.097	-0.164	-0.111
R1	1.182	0.879	0	0	0	0	0	-0.003	0	0	0	0	0	0	0	0	0.002	0.001

OTHER [euro/veh]

KEN	0.504	0.394	-0.065	-0.071	-0.089	-0.061	-0.009	-0.012	-0.090	-0.063	-0.091	-0.064	-0.016	-0.010	-0.075	-0.072	-0.110	-0.072
OWV	N	N	N	N	N	N	N	N	N	N	0.788	0.698	0.564	0.545	0.593	0.572	0.665	0.617
LFK	0.874	0.817	0.131	0.126	0.277	0.186	0.017	0.019	0.246	0.164	-0.113	-0.070	-0.021	-0.011	0.042	0.051	0.079	0.034
R2	0.778	0.570	-0.054	-0.059	-0.091	-0.063	-0.011	-0.015	-0.085	-0.060	-0.092	-0.066	-0.016	-0.010	-0.063	-0.061	-0.102	-0.069
R1	0.737	0.548	0	0	0	0	0	-0.002	0	0	0	0	0	0	0	0	0.001	0.001

FREIGHT [euro/veh]

KEN	3.662	2.862	N	N	-0.644	-0.440	-0.063	-0.086	-0.653	-0.454	-0.660	-0.465	-0.115	-0.071	N	N	-0.797	-0.524
OWV	N	N	N	N	N	N	N	N	N	N	5.725	5.072	4.094	3.962	4.309	4.157	4.830	4.480
LFK	6.347	5.934	0.952	0.918	2.012	1.353	0.122	0.136	1.785	1.191	-0.818	-0.507	-0.155	-0.077	0.305	0.373	0.570	0.247
R2	5.655	4.142	-0.391	-0.427	-0.661	-0.456	-0.078	-0.108	-0.618	-0.437	-0.672	-0.478	-0.117	-0.073	-0.458	-0.441	-0.743	-0.501
R1	5.356	3.980	0.001	0	0	0	0.001	-0.015	0.001	0.001	0.002	0.001	0.000	0.000	0.002	0.001	0.009	0.004

Table D-1: Time costs for BAU and changes in time costs for different scenarios compared to BAU

Scenarios	Name	BAU		A1		A2		A3		A4		B0		B1		B2		B3	
	OWV	No		No		No		No		No		Yes		Yes		Yes		Yes	
	Toll regime	LFK		LFK		No		RR LFK		KEN LFK		LFK		OWV LFK		OWV LFK		OWV LFK KEN	
	Freightban	FREE		BAN		FREE		FREE		FREE		FREE		FREE		BAN		FREE	
	Peak	Off-P	Peak	Off-P	Peak	Off-P	Peak	Off-P	Peak	Off-P	Peak	Off-P	Peak	Off-P	Peak	Off-P	Peak	Off-P	

WORK [euro/veh]

KEN	2.265	2.088	-0.105	-0.113	-0.142	-0.097	-0.014	-0.019	0.456	0.500	-0.146	-0.103	-0.025	-0.016	-0.120	-0.116	0.424	0.484
OWV	N	N	N	N	N	N	N	N	N	N	3.864	3.720	5.924	5.895	5.971	5.938	4.266	4.189
LFK	8.241	8.150	0.210	0.203	-2.756	-2.901	0.027	0.030	-1.806	-1.937	-0.181	-0.112	-0.034	-0.017	0.067	0.082	-2.074	-2.145
R2	3.328	2.994	-0.086	-0.094	-0.146	-0.101	-0.017	-0.024	-0.136	-0.096	-0.148	-0.106	-0.026	-0.016	-0.101	-0.097	-0.164	-0.111
R1	3.262	2.959	0	0	0	0	0	-0.003	0	0	0	0	0	0	0	0.000	0.002	0.001

OTHER [euro/veh]

KEN	1.960	1.850	-0.065	-0.071	-0.089	-0.061	-0.009	-0.012	0.510	0.537	-0.091	-0.064	-0.016	-0.010	-0.075	-0.072	0.490	0.528
OWV	N	N	N	N	N	N	N	N	N	N	3.388	3.298	5.584	5.565	5.613	5.592	3.865	3.817
LFK	8.914	8.857	0.131	0.126	-4.123	-4.214	0.017	0.019	-3.154	-3.236	-0.113	-0.070	-0.021	-0.011	0.042	0.051	-3.321	-3.366
R2	2.858	2.650	-0.054	-0.059	-0.091	-0.063	-0.011	-0.015	-0.085	-0.060	-0.092	-0.066	-0.016	-0.010	-0.063	-0.061	-0.102	-0.069
R1	2.817	2.628	0	0	0	0	0	-0.002	0	0	0	0	0	0	0	0	0.001	0.001

FREIGHT [euro/veh]

KEN	5.902	5.102	0.001	0	-0.644	-0.440	0.497	0.474	1.272	1.471	-0.660	-0.465	-0.115	-0.071	0.002	0.001	1.128	1.401
OWV	N	N	N	N	N	N	N	N	N	N	9.725	9.072	21.044	20.912	21.259	21.107	10.755	10.405
LFK	24.845	24.432	0.952	0.918	-10.886	-11.545	0.122	0.136	-7.962	-8.556	-0.818	-0.507	-0.155	-0.077	0.305	0.373	-9.177	-9.500
R2	8.855	7.342	-0.391	-0.427	-0.661	-0.456	0.727	0.697	-0.618	-0.437	-0.672	-0.478	-0.117	-0.073	-0.458	-0.441	-0.743	-0.501
R1	8.556	7.180	0.001	0	0	0	0.806	0.790	0.001	0.001	0.002	0.001	0	0	0.002	0.001	0.009	0.004

Table D-2: Generalised costs for BAU and changes in generalised costs for different scenarios compared to BAU

